

## PSEN op67-69K

### Bedienungsanleitung

## Allgemeines

Beim Zubehör PSEN op67-69K handelt es sich um eine PMMA-Acrylröhre, die zum Schützen und Abdichten der Sicherheitslichtvorhänge der Serien PSEN opxx-s-xx-xxx/1 und PSEN opxB-x-xxx verwendet wird. Dank des Zubehörs PSEN op67-69K kann die Schutzart des Sicherheitslichtvorhangs auf bis zu IP67 und IP69K erhöht werden.

Die in die Endkappen integrierte Gore-Tex-Membrane verhindert die Kondensatbildung im Innern ohne dass Wasser und Schmutz von außen eindringt. Die Dichtigkeit über das elektrische Anschlusskabel wird durch eine M16-Kabelverschraubung gewährleistet.

2 drehbare Halter aus Edelstahl, die an den Endkappen des Produkts zu montieren sind, sind im Lieferumfang enthalten und garantieren eine schnelle und einfache Installation.

## Übersicht

### Merkmale

- ▶ Schutzart IP67, IP68 und IP69K
- ▶ PMMA-Acrylröhre
- ▶ Profil mit unterschiedlichen Längen, geeignet für alle einstellbaren Höhen (150 bis 1.800 mm) und Mehrstrahllichtschranken für 2, 3 und 4 Lichtstrahle
- ▶ keine Beeinträchtigung der Leistungsfähigkeit des Lichtvorhangs hinsichtlich Ausrichtung
- ▶ keine Veränderung des EAA-Werts

### Typische Anwendungsbereiche

PSEN op67-69K ist besonders dort geeignet, wo hohe Luftfeuchtigkeit und Temperaturen vorherrschen und Maschinen und Anlagen oft mit Heißwasser (bis 80 °C) bei Hochdruck (bis 100 bar) und/oder mit Reinigungsmittel gereinigt werden.

PSEN op67-69K ist besonders für Anwendungen in der LEBENSMITTELINDUSTRIE geeignet: Getränkeherstellung, Schlachtung, Wurstherstellung, Molkereiindustrie usw.

## PSEN op67-69K

### Bedienungsanleitung

---

DE

#### Lieferumfang

Im Paket sind folgende Teile enthalten:

- ▶ transparente PMMA-Röhre (1 St.)
- ▶ untere Halterung (1 St.)
- ▶ obere Halterung (1 St.)
- ▶ Endkappe mit Silikonverbindung OR (2 St.)
- ▶ INOX drehbare Halter (2 St.)
- ▶ Schrauben und Muttern:
  - Vierkantmutter M5 (4 St.)
  - Schraube TE M5x6 UNI 5739 (4 St.)
  - elastische Metallscheibe UNI 8842 J5 (4 St.)
  - Schraube INOX TCEI M4x8 UNI 593 (6 St.)
  - Metallscheibe A4 UNI 8840 ZB (6 St.)
  - Schraube INOX TCEI M4x18 UNI 5931 (8 St.)

Unterbaugruppen b-d und c-d sind vorinstalliert und in die PMMA-Röhre a eingebaut, um die Stabilität des Pakets zu steigern.

## PSEN op67-69K

### Bedienungsanleitung

DE

## Montage

Zuerst Endkappen d von Unterbaugruppen b und c und danach die genannten Unterbaugruppen b und c von Röhre a entfernen. Nach diesen Arbeitsschritten ergibt sich der in Abb. 1 dargestellte Zustand.



Abb. 1

Vierkantmuttern M5 an der Innenseite der Halterungsflügel fluchtend mit den Löchern ansetzen und mit Schrauben TE M5x6 UNI 5739 (und Spezial-Unterlegscheiben) anschrauben, aber nicht festziehen, so dass Bewegungsspielraum bleibt (Abb. 2 und Abb. 3).

## PSEN op67-69K

### Bedienungsanleitung

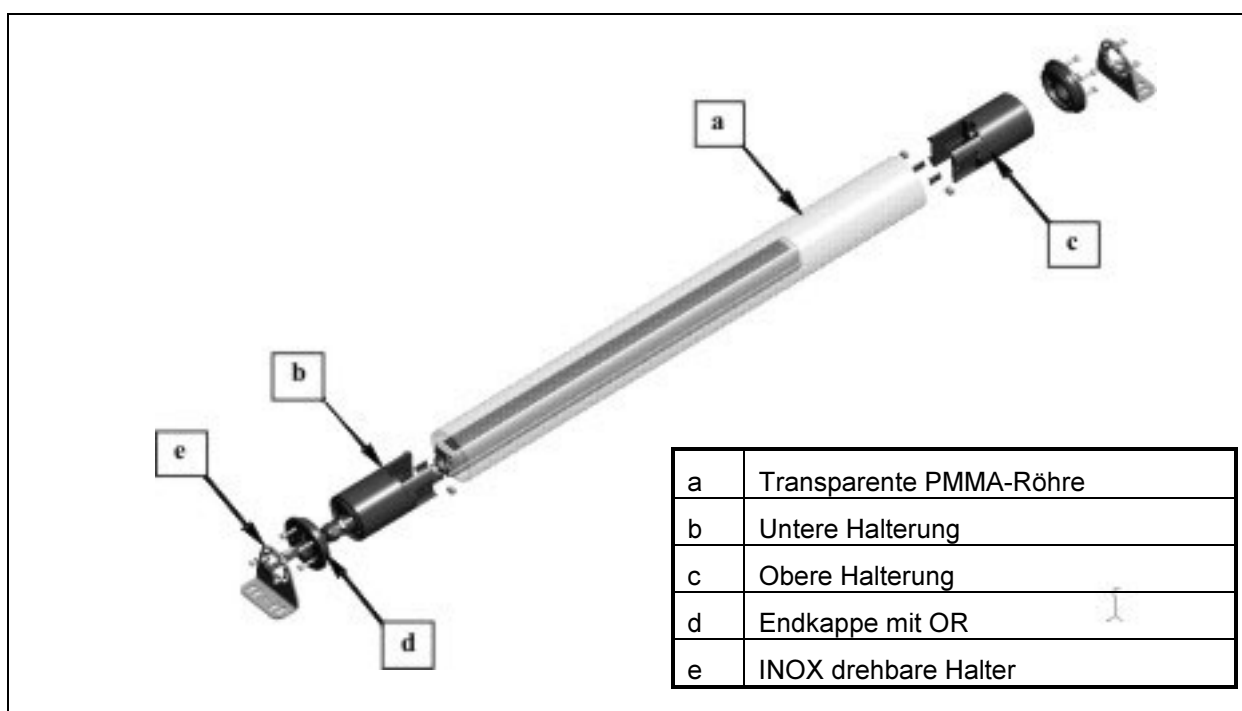
DE



Abb. 2



Abb. 3

Danach die Zwischenstücke in die seitlichen Nuten des PILZ Sicherheitslichtvorhangs bis zur Rückseite einschieben (Abb. 4) und die Schrauben zur Befestigung des Lichtvorhangs mit **c** anziehen. Den gleichen Arbeitsschritt auch für Teil **b** wiederholen; darauf achten, dass das Kabel des Sicherheitslichtvorhangs (das vor diesem Montagevorgang an den Vorhang anzuschließen ist) durch das entsprechende Loch der Kabelführung M16 verlegt ist, bevor die Schrauben angezogen werden (Abb. 5).

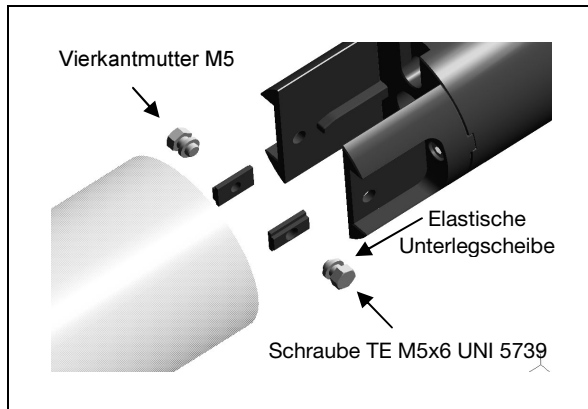

Abb. 4

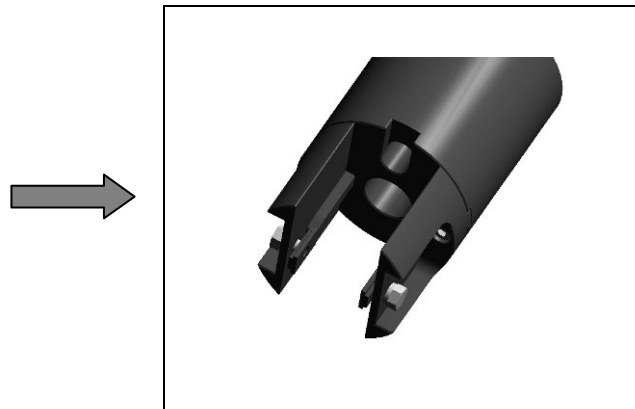
Abb. 5

Sind beide Teile **b** und **c** komplett mit dem Vorhang installiert, die Mutter zur Befestigung des Kabels festziehen. Noch einmal Schrauben M5x6 UNI TE 5739 auf Festsitz prüfen. Sieht das System aus, wie in Abb. 6 gezeigt, kann es in die transparente Röhre eingesetzt werden (Abb. 7).

## PSEN op67-69K

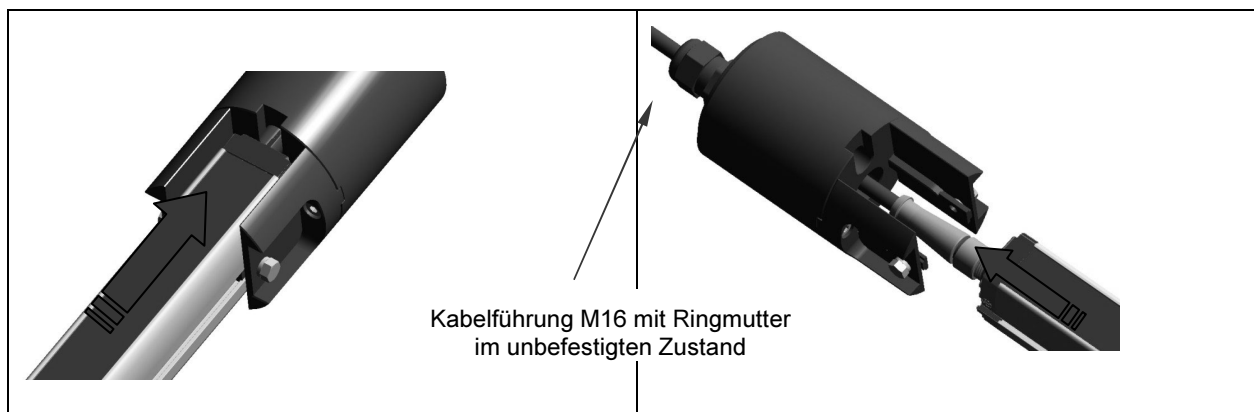
### Bedienungsanleitung

DE



Abb. 6

Abb. 7

Jetzt die beiden Endkappen mit der entsprechenden OR-Dichtung, wie in Abb. 8 gezeigt, vorbereiten und auf die Ober- und Unterseiten der PMMA-Röhre anbringen.

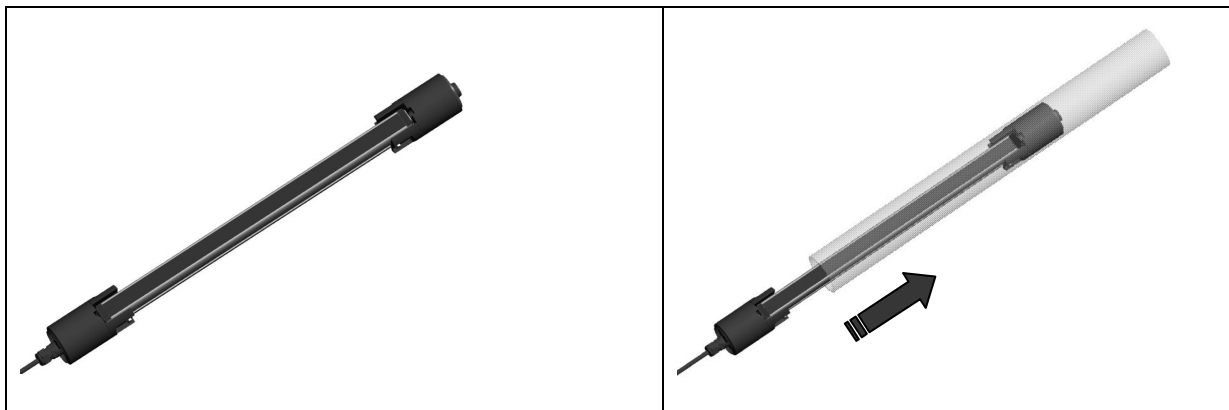

Abb. 8

Abb. 9

Die Montage durch Festziehen der 4 Schrauben INOX TCEI M4x18 UNI 5931 auf beiden Seiten fertigstellen, sodass die OR-Dichtung komplett gegen die Innenfläche der Röhre gedrückt wird (Abb. 9).

Zur Montage der Halter diese auf beide Endkappen fluchtend mit dem mittleren Loch des jeweiligen Halters positionieren und diese in der gewünschten Schräglage mit 3 Schrauben INOX TCEI M4x8 UNI 5931 (Abb. 10) festschrauben.

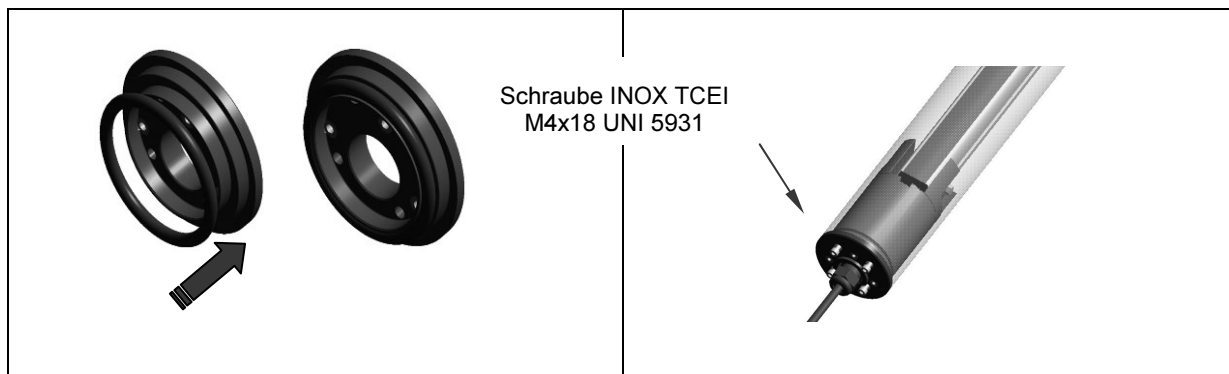

## PSEN op67-69K

### Bedienungsanleitung

DE

## Technische Daten

### Technische Daten PSEN op67-68K

OPTISCHE DATEN	
Nutzbare Reichweite/Reduktionsfaktor:	10 % pro Einheit
Abweichung EAA (Effektiver Abstrahlwinkel)	keine
MECHANISCHE DATEN	
Gehäusematerial:	Weep-Spin-Dry Policril PMMA (Polymethylmethacrylat, Acrylglas)
Dicke	4 mm
Schutzart	IP67, IP68 und IP69K

### Verfügbare Modelle

MODELL	Zugehörige Sicherheitslichtvorhänge	Bestell-Nr.
PSEN op67-69K-015/1	PSEN opxx-s-xx-015/1	630930
PSEN op67-69K-030/1	PSEN opxx-s-xx-030/1	630931
PSEN op67-69K-045/1	PSEN opxx-s-xx-045/1	630932
PSEN op67-69K-060/1	PSEN opxx-s-xx-060/1	630933
PSEN op67-69K-075/1	PSEN opxx-s-xx-075/1	630934
PSEN op67-69K-090/1	PSEN opxx-s-xx-090/1	630935
PSEN op67-69K-105/1	PSEN opxx-s-xx-105/1	630936
PSEN op67-69K-120/1	PSEN opxx-s-xx-120/1	630937
PSEN op67-69K-135/1	PSEN opxx-s-xx-135/1	630938
PSEN op67-69K-150/1	PSEN opxx-s-xx-150/1	630939
PSEN op67-69K-165/1	PSEN opxx-s-xx-165/1	630940
PSEN op67-69K-180/1	PSEN opxx-s-xx-180/1	630941
PSEN op67-69K-2-050	PSEN opxB-2-050	630942
PSEN op67-69K-3-080	PSEN opxB-3-080	630943
PSEN op67-69K-4-090	PSEN opxB-4-090	630944
PSEN op67-69K-4-120	PSEN opxB-4-120	630945

## PSEN op67-69K

### Bedienungsanleitung

DE

#### Abmessungen



Abb. 13

MODELL	L (mm)
PSEN op67-69K-015/1	373,5
PSEN op67-69K-030/1	520,7
PSEN op67-69K-045/1	670,8
PSEN op67-69K-060/1	820,7
PSEN op67-69K-075/1	970,8
PSEN op67-69K-090/1	1120,7
PSEN op67-69K-105/1	1270,7
PSEN op67-69K-120/1	1420,8
PSEN op67-69K-135/1	1570,7
PSEN op67-69K-150/1	1720,8
PSEN op67-69K-165/1	1870,8
PSEN op67-69K-180/1	2020,8
PSEN op67-69K-2-050	793,5
PSEN op67-69K-3-080	1093,5
PSEN op67-69K-4-090	1193,5
PSEN op67-69K-4-120	1493,5

## PSEN op67-69K

### Bedienungsanleitung

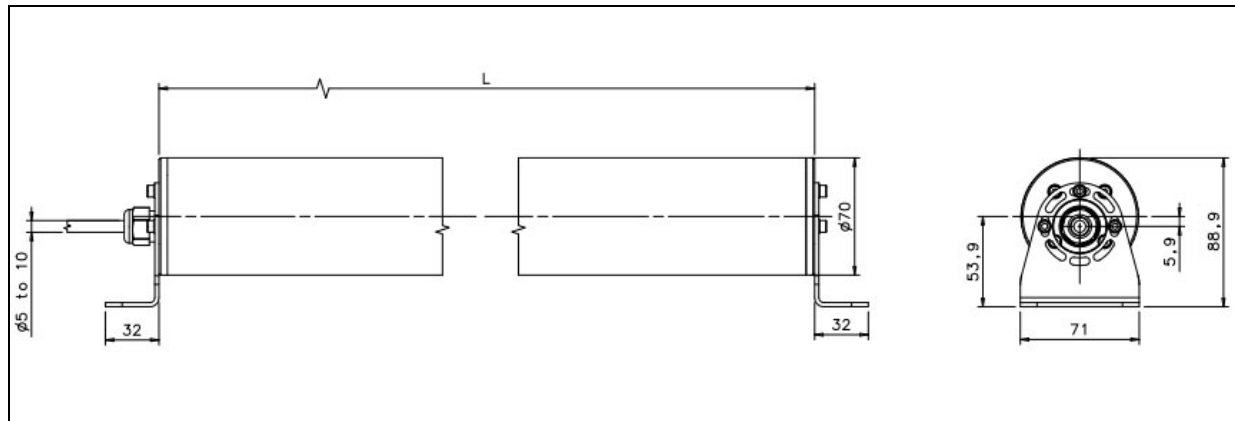
DE

## Chemische Beständigkeit

Legende:

FR: full resistance

MR: medium resistance

NR: no resistance

DISINFECTANTS	CONCENTRATION	RESISTANCE
Hydrogen peroxide 100 volumns		FR
Turpentine		FR
Trichloroethylene		NR
Tricresisolfato		NR
Triethylamina		FR
Xylol		NR
<b>GAS</b>		
Ammonia		FR
Carbon dioxide		FR
Sulfur trioxide		FR
Sulfur dioxide		FR
Nitrogen dioxide		FR
Gas illuminante		FR
Hydrogen sulfide		FR
Methane		FR
Carbon monoxide		FR
Oxygen		FR
Ozone		FR
Bromine vapors		MR
Chlorine vapors		MR
<b>FOODS</b>		
Vinegar		FR
Water		FR
Mineral water		FR
Anise		FR
Beer		FR
Coffee		FR
Cinnamon		FR
Chocolate		FR
Onion		FR
Chamomile extract		FR
Lauro leaves		FR
Dianthus		NR
Milk of Lime		FR
Liquors		NR
Nutmeg		FR
Pepper		FR
Cider		FR
Juice		FR
Wine		FR

## PSEN op67-69K

### Bedienungsanleitung

DE

INORGANIC ACID	CONCENTRATION	RESISTANCE
Boric acid		FR
Hydrochloric acid	< 40%	FR
Chromic acid	< 40%	FR
Chlorosulfuric acid		FR
Hydrogen fluoride	< 40%	MR
Phosphoric acid	< 30%	FR
Nitric Acid	< 20%	MR
Concentrate nitric acid		NR
Sulfuric acid	< 40%	FR
Sulfuric acid	< 80%	MR
Sulfuric acid	1%	FR
Acid for accumulators		FR
<b>ALKALINE ACID</b>		
Ammoniac		FR
Barium hydrate, saturate solution		FR
Potassic Carbonate, saturate solution		MR
Soda Ash, saturate solution		FR
Milk of Lime		FR
Caustic Potassium, whatever concentration		MR
Sodium hydroxide, whatever concentration		FR
<b>INORGANIC SUBSTANCES</b>		
Chlorine water		FR
Hydrogen peroxide 40 volums		FR
Hydrogen peroxide 120 volums		NR
Aluminium Chloride		FR
Aluminium fluoride		MR
Aluminium oxalate		FR
Aluminium sulphate		FR
Potassium alum		FR
Ammonium carbonate		FR
Ammonium chloride		FR
Ammonium fluoride		FR
Ammonium nitrate		FR
Ammonium sulphate		FR
Argent nitrate		FR
Barium Chloride		FR
Barium sulphate		FR
Calcium Chloride		FR
Calcium hypochlorite		MR
Liquid Chlorine		NR
Sulfuryl chloride		NR
Ferric chloride (ico)		FR
Ferric chloride (oso)		FR
Ferric sulphate (oso)		FR
Magnesium Chloride		FR
Magnesium Sulphate		FR

## PSEN op67-69K

### Bedienungsanleitung

DE

ORGANIC ACIDS	CONCENTRATION	RESISTANCE
Concentrated acetic acid		NR
Acetyl acid	< 10%	FR
Butyric acid	< 5%	FR
Formic acid		NR
Formic acid	< 2%	FR
Lactic acid	< 10%	FR
Oxalic acid		FR
Picric acid	1% (in water)	FR
Stearic acid		FR
Tartaric acid	< 20%	FR
Thioglycolic acid	< 10%	MR
Trichloroacetic acid		NR
Ethyl acetate		NR
Acetone		NR
Alcool allilico		NR
Alcool amilico		NR
N-Butanol		NR
Ethyl alcohol	< 20%	FR
Ethyl alcohol		NR
Isopropyl alcohol		NR
Wood alcohol		NR
1-propyl alcohol		NR
Acetic aldehyde		NR
Acetic anhydride		NR
Formaldehyde		FR
Aniline		NR
Benzine		MR
Benzole		NR
Ethyl bromide		NR
Butirrato di etile		NR
Chlorophenol		NR
Chloroform		NR
Ethyl chloride		NR
Aviation gasoline		MR
Cresol, methyl phenol		NR
Decalina		FR
Diacetonalcool		NR
1,4-Dioxane		NR
Ethylene bromide		NR
Bis(2-ethylhexyl) phthalate		MR
Heptane		FR
Esalina		FR
Hexane		FR
ThilChloroether		NR
Petroleum ether		FR
Phenol		FR
Ethyl ether		NR
Ftalato diamilico		NR
Ftalato dibutilico		NR
Glycerine		FR
2-etandiolo		FR
Butyl lactate		NR
Methyl ethyl ketone		NR
Monobromo naftalina		FR
Naphthalene		FR
Pyridine		NR
Propylene, methyl ethylene, propene		NR
Carbon disulfide		NR
Freon		NR
Tetrachloroethylene		NR
Carbon tetrachloride		NR
Tetrahydrofuran		NR
Tetralina		NR
Tolulo		NR

## PSEN op67-69K

### Bedienungsanleitung

DE

SOLVENTS E ORGANIC COMPOUNDS	CONCENTRATION	RESISTANCE
Amyl acetate		NR
Manganese(II) sulfate		FR
Mercury sulphate		MR
Nickel sulphate		FR
Potassium bicarbonate		FR
Potassium dichromate		FR
Potassium carbonate		FR
Potassium cyanide		FR
Potassium ferricyanide		FR
Niter (saltpeter)		FR
Potassium permanganate		FR
Potassium sulfite		FR
Potassium sulfate		FR
Copper(II) chloride		FR
Copper sulphate		FR
Silicon tetrachloride		NR
Sodium bisulphite		FR
Sodium cyanide		FR
Sodium chlorate		FR
Sodium Cloride		FR
Sodium fluoride		FR
Sodium phosphate		MR
Sodium hypochlorite		MR
Sodium nitrate		FR
Sodium sulphate		FR
Sodium sulphur		FR
Tin chloride (oso)		FR
Tin chloride (ico)		FR
Tin sulphate (ico)		FR
Zinc sulphate		FR
Zinc chloride		FR
Sulphur		FR
FATS, OILS, WAX	CONCENTRATION	RESISTANCE
Refining fatty acid		FR
Floor wax		MR
Diesel oil		FR
Vegetable oils and fats		FR
Mineral oils		FR
Moneral oils and fats		FR
Transformer oil		FR
DETERGENTS		
Alcool	< 20%	FR
Carbolic acid		NR
DDT (dichlorodiphenyltrichloroethane)		MR
Formalia (se è formalina = Formaldehide)		FR
Pasta di cloramina		NR
Calcium hypochlorite pulp		FR
Ethanol denaturated		NR
Soluzione cloramina	< 2%	FR
Calcium chloride solution	< 2%	FR
Mercury(II) chloride		FR
Alcool anidro		NR
Pure gasoline		NR
Sodium hypochlorite		FR
Solvent stain remover		NR
Ammonia water solution		FR

## PSEN op67-69K

### Operating instructions

---

#### General

The accessory PSEN op67-69K is a PMMA acrylic tube, which is used to protect and seal safety light curtains in the series PSEN opxx-s-xx-xxx/1 and PSEN opxB-x-xxx. Thanks to the accessory PSEN op67-69K, the protection type of the safety light curtain can be increased to up to IP67 and IP69K.

A Gore-Tex membrane is integrated into the end cap, stopping condensation from forming inside and preventing the ingress of water and dirt. Seal tightness across the electrical connection cable is guaranteed by an M16 cable screw connection.

2 rotating, stainless steel brackets are supplied with the unit and are to be mounted on the product's end caps to guarantee simple, fast installation.

#### Overview

##### Features

- ▶ Protection type IP67, IP68 and IP69K
- ▶ PMMA acrylic tube
- ▶ Profile in a range of lengths, suitable for all selectable heights (150 to 1,800 mm) as well as multi-beam light beam devices for 2, 3 and 4 light beams
- ▶ Does not adversely affect the performance of the light curtain in terms of alignment
- ▶ Does not change the EAA value

##### Typical application areas

PSEN op67-69K is particularly suitable where high humidity and temperatures prevail and where plant and machinery are regularly cleaned using hot water (up to 80 °C), at high pressure (up to 100 bar) and/or using detergents.

PSEN op67-69K is particularly suitable for applications in the FOOD INDUSTRY: Manufacture of beverages, slaughtering, meat processing, dairy industry etc.

## PSEN op67-69K

### Operating instructions

---

EN

#### Scope of supply

The package contains the following components:

- ▶ Transparent PMMA tube (1 piece)
- ▶ Lower bracket (1 piece)
- ▶ Upper bracket (1 piece)
- ▶ End cap with silicon compound OR (2 pieces)
- ▶ INOX rotating bracket (2 pieces)
- ▶ Screws and nuts:
  - M5 square nut (4 pieces)
  - TE M5x6 UNI 5739 screw (4 pieces)
  - UNI 8842 J5 metallic elastic washer (4 pieces)
  - INOX TCEI M4x8 UNI 593 screw (6 pieces)
  - A4 UNI 8840 ZB metallic washer (6 pieces)
  - INOX TCEI M4x18 UNI 5931 screw (8 pieces)

Subassemblies b-d and c-d are pre-installed and built into the PMMA tube, to increase the stability of the package.

## PSEN op67-69K

### Operating instructions

EN

#### Assembly

First of all, remove end caps d from subassemblies b und c and then remove subassemblies b and c from tube a. Having taken these steps, the unit should be in the condition illustrated in Fig. 1.

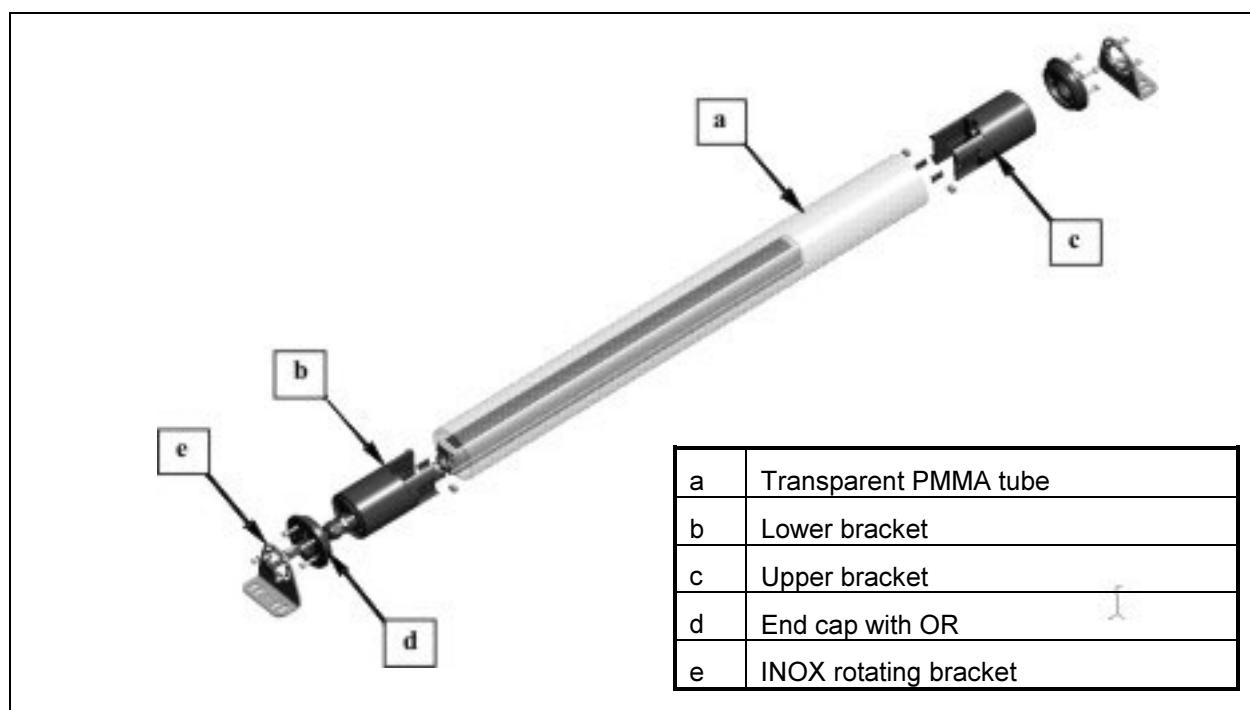

Fig. 1

Position the M5 square nuts on the inside of the bracket blade, aligned with the holes, and affix the screws TE M5x6 UNI 5739 (and special washers), but do not tighten them, leaving room for manoeuvre (Fig. 2 and Fig. 3).

## PSEN op67-69K

### Operating instructions

EN

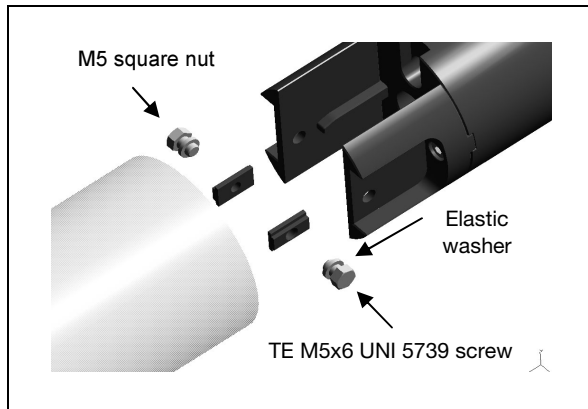

Fig. 2

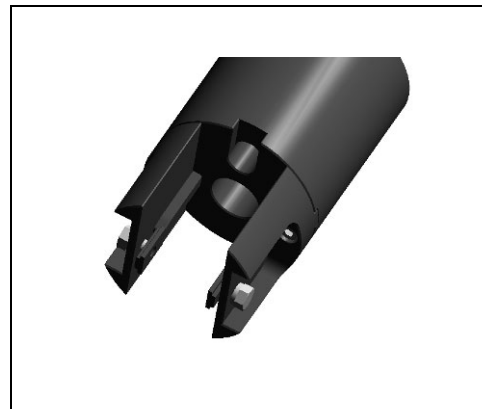

Fig. 3

Then insert the spacers into the lateral grooves of the PILZ safety light curtain as far as the end (Fig. 4) and tighten the screws to attach the light curtain to **c**. Repeat the same step for part **b**; make sure that the safety light curtain cable (which must be connected before starting the light curtain assembly) is guided through the relevant hole of the M16 cable conduit before tightening the screws (Fig. 5).

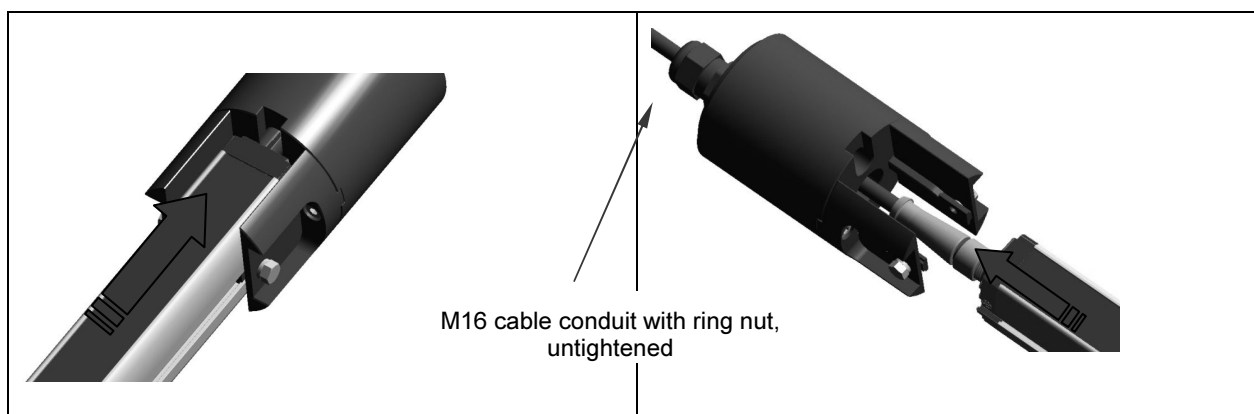

Fig. 4

Fig. 5

When both parts **b** and **c** are fully installed on the light curtain, tighten the nut to secure the cable. Check again that the M5x6 UNI TE 5739 screws are firmly seated.

If the system looks like the illustration in Fig. 6, it can be placed inside the transparent tube (Fig. 7).

## PSEN op67-69K

### Operating instructions

EN

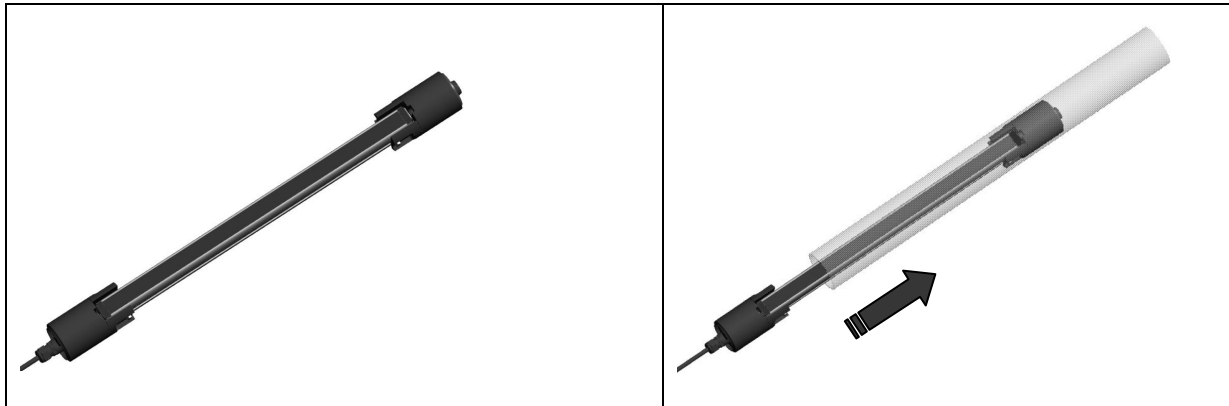

Fig. 6

Fig. 7

Now prepare the two end caps with the relevant OR gasket, as illustrated in Fig. 8, and attach to the top and bottom of the PMMA tube.



Fig. 8

Fig. 9

Complete the assembly by tightening the 4 screws INOX TCEI M4x18 UNI 5931 on both sides, so that the OR gasket is completely pressed against the inside of the tube (Fig. 9).

To install the brackets, position them on both end caps, aligned with the middle hole of the respective bracket, and tighten them in the required angular position using the 3 screws INOX TCEI M4x8 UNI 5931 (Fig. 10).

## PSEN op67-69K

### Operating instructions

EN

The bracket is designed so as to allow all the "main positions", with an average angle adjustment range of 20 to 30 degrees, depending on the required position (Fig. 11 and Fig. 12).

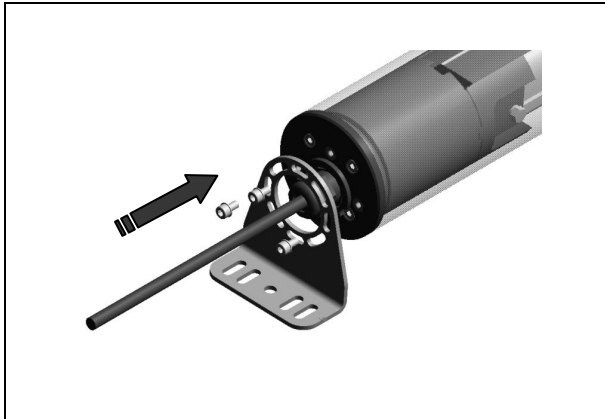

Fig. 10

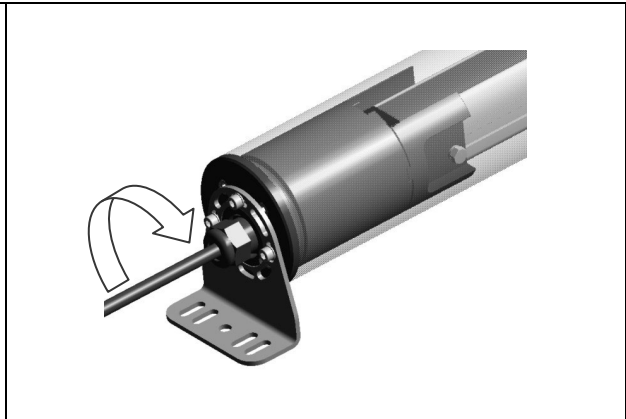

Fig. 11

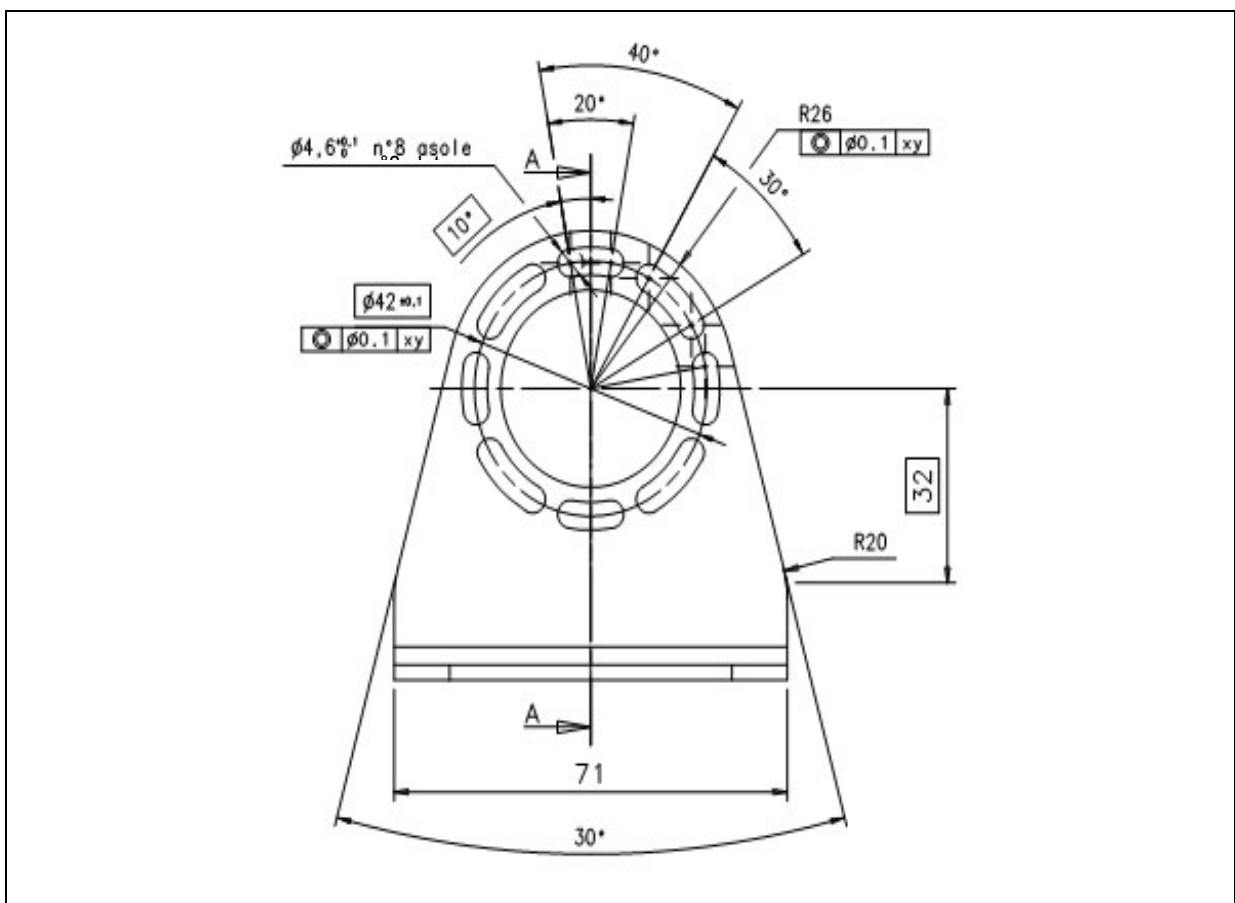

Fig. 12

## PSEN op67-69K

### Operating instructions

EN

## Technical details

### Technical details PSEN op67-68K

OPTICAL DATA	
Usable operating range/reduction factor:	10 % per unit
EAA deviation (effective aperture angle)	None
MECHANICAL DATA	
Housing material:	Weep-spin-dry policril PMMA (polymethyl methacrylate, acrylic glass)
Thickness	4 mm
Protection type	IP67, IP68 and IP69K

### Available models

MODEL	Corresponding safety light curtains	Order no.
PSEN op67-69K-015/1	PSEN opxx-s-xx-015/1	630930
PSEN op67-69K-030/1	PSEN opxx-s-xx-030/1	630931
PSEN op67-69K-045/1	PSEN opxx-s-xx-045/1	630932
PSEN op67-69K-060/1	PSEN opxx-s-xx-060/1	630933
PSEN op67-69K-075/1	PSEN opxx-s-xx-075/1	630934
PSEN op67-69K-090/1	PSEN opxx-s-xx-090/1	630935
PSEN op67-69K-105/1	PSEN opxx-s-xx-105/1	630936
PSEN op67-69K-120/1	PSEN opxx-s-xx-120/1	630937
PSEN op67-69K-135/1	PSEN opxx-s-xx-135/1	630938
PSEN op67-69K-150/1	PSEN opxx-s-xx-150/1	630939
PSEN op67-69K-165/1	PSEN opxx-s-xx-165/1	630940
PSEN op67-69K-180/1	PSEN opxx-s-xx-180/1	630941
PSEN op67-69K-2-050	PSEN opxB-2-050	630942
PSEN op67-69K-3-080	PSEN opxB-3-080	630943
PSEN op67-69K-4-090	PSEN opxB-4-090	630944
PSEN op67-69K-4-120	PSEN opxB-4-120	630945

## PSEN op67-69K

### Operating instructions

EN

#### Dimensions

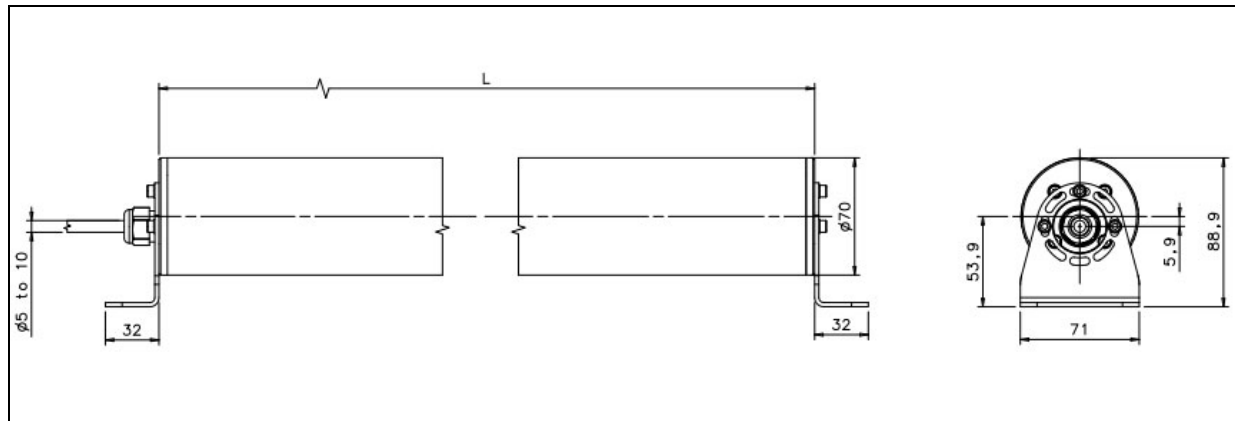

Fig. 13

MODEL	L (mm)
PSEN op67-69K-015/1	373.5
PSEN op67-69K-030/1	520.7
PSEN op67-69K-045/1	670.8
PSEN op67-69K-060/1	820.7
PSEN op67-69K-075/1	970.8
PSEN op67-69K-090/1	1120.7
PSEN op67-69K-105/1	1270.7
PSEN op67-69K-120/1	1420.8
PSEN op67-69K-135/1	1570.7
PSEN op67-69K-150/1	1720.8
PSEN op67-69K-165/1	1870.8
PSEN op67-69K-180/1	2020.8
PSEN op67-69K-2-050	793.5
PSEN op67-69K-3-080	1093.5
PSEN op67-69K-4-090	1193.5
PSEN op67-69K-4-120	1493.5

## PSEN op67-69K

### Operating instructions

EN

### Chemical resistance

Legend:

FR: full resistance

MR: medium resistance

NR: no resistance

DISINFECTANTS	CONCENTRATION	RESISTANCE
Hydrogen peroxide 100 volumns		FR
Turpentine		FR
Trichloroethylene		NR
Tricresilolato		NR
Trietillamina		FR
Xylol		NR
<b>GAS</b>		
Ammonia		FR
Carbon dioxide		FR
Sulfur trioxide		FR
Sulfur dioxide		FR
Nitrogen dioxide		FR
Gas illuminante		FR
Hydrogen sulfide		FR
Methane		FR
Carbon monoxide		FR
Oxygen		FR
Ozone		FR
Bromine vapors		MR
Chlorine vapors		MR
<b>FOODS</b>		
Vinegar		FR
Water		FR
Mineral water		FR
Anise		FR
Beer		FR
Coffee		FR
Cinnamon		FR
Chocolate		FR
Onion		FR
Chamomile extract		FR
Lauro leaves		FR
Dianthus		NR
Milk of Lime		FR
Liquors		NR
Nutmeg		FR
Pepper		FR
Cider		FR
Juice		FR
Wine		FR

## PSEN op67-69K

### Operating instructions

EN

INORGANIC ACID	CONCENTRATION	RESISTANCE
Boric acid		FR
Hydrochloric acid	< 40%	FR
Chromic acid	< 40%	FR
Chlorosulfuric acid		FR
Hydrogen fluoride	< 40%	MR
Phosphoric acid	< 30%	FR
Nitric Acid	< 20%	MR
Concentrate nitric acid		NR
Sulfuric acid	< 40%	FR
Sulfuric acid	< 80%	MR
Sulfuric acid	1%	FR
Acid for accumulators		FR
<b>ALKALINE ACID</b>		
Ammoniac		FR
Barium hydrate, saturate solution		FR
Potassic Carbonate, saturate solution		MR
Soda Ash, saturate solution		FR
Milk of Lime		FR
Caustic Potassium, whatever concentration		MR
Sodium hydroxide, whatever concentration		FR
<b>INORGANIC SUBSTANCES</b>		
Chlorine water		FR
Hydrogen peroxide 40 volums		FR
Hydrogen peroxide 120 volums		NR
Aluminium Chloride		FR
Aluminium fluoride		MR
Aluminium oxalate		FR
Aluminium sulphate		FR
Potassium alum		FR
Ammonium carbonate		FR
Ammonium chloride		FR
Ammonium fluoride		FR
Ammonium nitrate		FR
Ammonium sulphate		FR
Argent nitrate		FR
Barium Chloride		FR
Barium sulphate		FR
Calcium Chloride		FR
Calcium hypochlorite		MR
Liquid Chlorine		NR
Sulfuryl chloride		NR
Ferric chloride (ico)		FR
Ferric chloride (oso)		FR
Ferric sulphate (oso)		FR
Magnesium Chloride		FR
Magnesium Sulphate		FR

## PSEN op67-69K

### Operating instructions

ORGANIC ACIDS	CONCENTRATION	RESISTANCE
Concentrated acetic acid		NR
Acetyl acid	< 10%	FR
Butyric acid	< 5%	FR
Formic acid		NR
Formic acid	< 2%	FR
Lactic acid	< 10%	FR
Oxalic acid		FR
Picric acid	1% (in water)	FR
Stearic acid		FR
Tartaric acid	< 20%	FR
Thioglycolic acid	< 10%	MR
Trichloroacetic acid		NR
Ethyl acetate		NR
Acetone		NR
Alcool allilico		NR
Alcool amilico		NR
N-Butanol		NR
Ethil alcohol	< 20%	FR
Ethyl alcohol		NR
Isopropyl alcohol		NR
Wood alcohol		NR
1-propyl alcohol		NR
Acetic aldehyde		NR
Acetic anhydride		NR
Formaldehyde		FR
Aniline		NR
Benzine		MR
Benzole		NR
Ethil bromide		NR
Butirrato di etile		NR
Chlorophenol		NR
Chloroform		NR
Ethil chloryde		NR
Aviation gasoline		MR
Cresol, methyl phenol		NR
Decalina		FR
Diacetonalcool		NR
1,4-Dioxane		NR
Ethylene bromide		NR
Bis(2-ethylhexyl) phthalate		MR
Heptane		FR
Esalina		FR
Hexane		FR
ThilChloroether		NR
Petroleum ether		FR
Phenol		FR
Ethyl ether		NR
Ftalato diamilico		NR
Ftalato dibutilico		NR
Glycerine		FR
2-etandiolo		FR
Butyl lactate		NR
Methyl ethyl ketone		NR
Monobromo naftalina		FR
Naphthalene		FR
Pyridine		NR
Propylene, methyl ethylene, propene		NR
Carbon disulfide		NR
Freon		NR
Tetrachloroethylene		NR
Carbon tetrachloride		NR
Tetrahydrofuran		NR
Tetralina		NR
Tolulo		NR

## PSEN op67-69K

### Operating instructions

EN

SOLVENTS E ORGANIC COMPOUNDS	CONCENTRATION	RESISTANCE
Amyl acetate		NR
Manganese(II) sulfate		FR
Mercury sulphate		MR
Nickel sulphate		FR
Potassium bicarbonate		FR
Potassium dichromate		FR
Potassium carbonate		FR
Potassium cyanide		FR
Potassium ferricyanide		FR
Niter (saltpeter)		FR
Potassium permanganate		FR
Potassium sulfite		FR
Potassium sulfate		FR
Copper(II) chloride		FR
Copper sulphate		FR
Silicon tetrachloride		NR
Sodium bisulphite		FR
Sodium cyanide		FR
Sodium chlorate		FR
Sodium Cloride		FR
Sodium fluoride		FR
Sodium phosphate		MR
Sodium hypochlorite		MR
Sodium nitrate		FR
Sodium sulphate		FR
Sodium sulphur		FR
Tin chloride (oso)		FR
Tin chloride (ico)		FR
Tin sulphate (ico)		FR
Zinc sulphate		FR
Zinc chloride		FR
Sulphur		FR
FATS, OILS, WAX	CONCENTRATION	RESISTANCE
Refining fatty acid		FR
Floor wax		MR
Diesel oil		FR
Vegetable oils and fats		FR
Mineral oils		FR
Moneral oils and fats		FR
Transformer oil		FR
DETERGENTS		
Alcool	< 20%	FR
Carbolic acid		NR
DDT (dichlorodiphenyltrichloroethane)		MR
Formalia (se è formalina = Formaldehide)		FR
Pasta di cloramina		NR
Calcium hypochlorite pulp		FR
Ethanol denaturated		NR
Soluzione cloramina	< 2%	FR
Calcium chloride solution	< 2%	FR
Mercury(II) chloride		FR
Alcool anidro		NR
Pure gasoline		NR
Sodium hypochlorite		FR
Solvent stain remover		NR
Ammonia water solution		FR